

USER MANUAL

Product implementation standards:
EN 61010-1 : 2010/A1:2019
EN 61010-2-011:2017
EN 61326-1 :2013

EN

ULT FREEZER

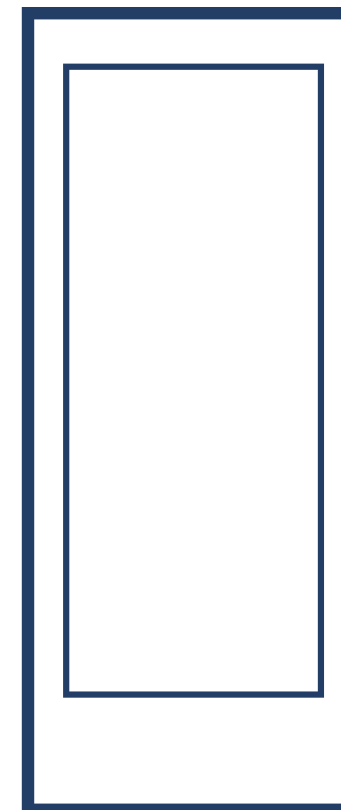

Warning:
Before using this product,
please read this manual carefully
and keep it for future reference.
The design and specifications
are subject to change without
prior notice for product
improvement. Consult with your
dealer or manufacturer for
details.

version:001-4-2023



Model: GL-U-16D
GL-U-19D
GL-U-25D
GL-U-30D

www.aegisfridge.com

Table of Contents

Safety warnings	1
Product Features	7
Precautions for Use	8
Product Installation	9
Product Components and Overview	12
Operating Instructions	14
Alarm Description	32
Maintenance	33
Troubleshooting and Repairs	35
Specifications	36
Packing List	38
Electrical Schematic Diagram	38
Service Guide	42

Safety warnings

Safety Warning Signs



Warning



Watch Your Hand



Electrocution Hazard!



Combustible Material



Frostbite Warning

- ❶ **WARNING:** The packaging base at the bottom of this series of products must be removed before use.
- ❷ **WARNING:** When moving this series of products, take care that the bottom foot does not touch the power cord.
- ❸ **WARNING:** The bottom front wheel brake of this series of products need to be locked after moving to the designated position.
- ❹ **WARNING:** This series of products need to be left to stand for 24 hours before initial power-up.
- ❺ **WARNING:** When this series of products are just connected to the power supply, do not immediately put the items in to it. After running for a period of time, when the temperature inside the ULT freezer drops to the set temperature, then put the items in batches.
- ❻ **Note:** A single batch of items put into the ULT freezer can not exceed 1/3 of the volume.
- ❼ **WARNING:** Keep all ventilation openings in the enclosure or, in the structure for building-in, clear of obstruction.
- ❽ **WARNING:** Do not use mechanical devices or other means to accelerate the defrosting process, other than those recommended by the manufacturer.
- ❾ **WARNING:** Do not damage the refrigerant circuit.
- ❿ **WARNING:** Please use grounded power outlets to prevent electric shocks. Ungrounded power outlets must be connected with grounding wires by professional technicians.
- ⓫ **WARNING:** This ULT freezer must be firmly placed on a solid and flat ground and proper care is taken to prevent overturning.
If the floor is not level or the ULT freezer is placed in an improper location, the ULT freezer may fall down and cause injuries.

- ❶ WARNING: In case of leakage of gas and other flammable gases, open the doors and windows to ventilate and exhaust gas. Do not plug or unplug the power plug of the ULT freezer, otherwise it may cause an explosion and fire.
- ❶ WARNING: Only professional technicians or maintenance personnel for after-sales support can disassemble and assemble the ULT freezer. Otherwise, it may electric shocked to cause a fire.
- ❶ WARNING: Please use the special power supply indicated on the nameplate of the ULT freezer, otherwise it may cause a fire or electric shock.
- ❶ WARNING: The power cord of this ULT freezer is equipped with a three-prong (grounded) plug to mate with a standard three-prong (grounded) outlet of 16A. Never remove the grounding pin of the power cord. Make sure that the power plug and the outlet are connected firmly and reliably, otherwise it may cause a fire.
- ❶ WARNING: When removing the plug from the power socket, you should hold the power plug instead of pulling the wire of the power plug. Otherwise, it may cause electric shock or fire due to short circuit.
- ❶ WARNING: If the ULT freezer is not operating properly, unplug the power plug. It may cause an electric shock or fire if the ULT freezer continues to operate under abnormal conditions.
- ❶ WARNING: Before any repair or maintenance of the ULT freezer, always disconnect the ULT freezer from the power supply to prevent electric shocks or personal injuries.
- ❶ WARNING: Make sure that the drugs or suspended particles inside and around the ULT freezer will not be inhaled during repairs and maintenance, otherwise it may cause harm to human health.
- ❶ WARNING: When storing toxic, harmful, or radioactive substances, please use the ULT freezer in a safe area. Improper use may cause harm to human health or the environment.
- ❶ WARNING: Disconnect the power plug when the ULT freezer is not in use for a long period, so as to prevent electric shock, electric leakage, or fire due to the deterioration of the power cord.
- ❶ WARNING: If the ULT freezer is to be stored unused in an unsupervised area for a long period, ensure that children do not have access to the ULT freezer.

The disposal of the ULT freezer shall be accomplished by the appropriate personnel. Remove doors to prevent accidents such as suffocation.

- ❗ **WARNING:** If CO₂/LN₂ standby system is used, a good ventilation environment must be provided at the installation and use site.
- ❗ **WARNING:** Increased carbon dioxide concentrations in the air can asphyxiate and endanger life safety. In case of poor ventilation, other methods must be considered to ensure a safe environment.
- ❗ **WARNING:** Do not leave the plastic packing bags in a place where they can be reached by small children as this may result in suffocation accidents.
- ❗ **WARNING:** Do not climb on the ULT freezer or put any objects on the ULT freezer, otherwise the ULT freezer may fall and cause injuries or cause damage to the ULT freezer.
- ❗ **WARNING:** Do not use the ULT freezer outdoors. Exposure to rain may cause an electric leakage or electric shock.
- ❗ **WARNING:** Do not place the ULT freezer in a humid location or a place where the ULT freezer is easy to be splashed with water. Otherwise, an electric leakage or electric shocks may be caused by the deterioration of insulation.
- ❗ **WARNING:** Do not pour water directly onto the ULT freezer, otherwise it may cause an electric shock or a short circuit.
- ❗ **WARNING:** Never disassemble, repair, or modify the ULT freezer yourself. Otherwise, fire or personal injuries may be caused by improper operation.
- ❗ **WARNING:** Do not connect the grounding wire to a gas pipe, power supply pip, telephone line, or lightning rod when grounding the ULT freezer. The above grounding methods will cause electric shocks or other hazards.
- ❗ **WARNING:** Do not touch any electrical parts such as the power plug or operate any switch with a wet hand, otherwise it may cause an electric shock.
- ❗ **WARNING:** Do not put water containers or heavy objects on the ULT freezer. Falling objects may cause personal injuries and spilled water may cause the insulation to be reduced and result in an electric leakage or electric shock.
- ❗ **WARNING:** Never insert metal objects such as iron nails and wires into any vent, gap, or air outlet on the ULT freezer. This may cause electric shocks or injuries by accidental contact of these objects with moving parts.

- ❶ WARNING: It is not allowed to tie, drag, pull, wind and bind the power cord, or damage the power cord plug. Damaged power cords or plugs may cause fire or electric shock.
- ❶ WARNING: The power cord with a loose plug is not allowed, because it may cause fire or electric shock.
- ❶ WARNING: It is not allowed to put glass bottles or canned items in the ULT freezer, which may be frozen and cracked, causing injury to personnel.
- ❶ Refrigerant and cyclopentane foaming material used for the appliance are flammable. Therefore, when the appliance is scrapped, it shall be kept away from any fire source and be recovered by a special recovering company with corresponding a qualification other than being disposed of by combustion, so as to prevent damage to the environment or any other harm.
- ❶ IMPORTANT:
Flammable gas and refrigerant used. It is the consumer's responsibility to comply with Federal and Local regulations when disposing of this product.
Suggestion: Cut off the pipeline and drain the refrigerant without any open fire around.



The product with the symbol reads "warning terms";



The product with this symbol reads "prevent fire, stay away from fire sources";

CYCLOPENTANE

The product with this symbol reads "cyclopentane blowing"

- Power supply voltage: This series of products use 220V-240V/50Hz AC power supply, if the use of voltage lower than 198V or higher than 264V, need to add a suitable automatic voltage regulator with the use(5kVA).
- Use of this series of products requires a low-voltage air circuit breaker and earth leakage protection device for the power supply.
- A special power socket must be used and reliable grounding must be carried out, and the length of the power line must not be arbitrarily extended. If extensions are required, copper-core conductors with a cross-sectional area of 2.5mm² or more must be used, and copper-core conductors in the wall connected to the power socket must also have a cross-sectional area of 4mm² or more.
- This series of products are strictly prohibited to put into flammable, explosive

dangerous goods and strong corrosive acid, alkali and other items;

- The keys of this series of products need to be properly stored to avoid accidents when children get them and open the door to play;
- Do not connect the neutral wire (N terminal) and the ground wire (E terminal) of the power socket together, otherwise it can cause the shell of this series of products to be charged and an electric shock accident can occur;
- The power cord cannot be bundled and used, cannot be pressed under heavy objects, and cannot be close to heat sources such as compressors.
- When it needs to restart the ULT freezer after the ULT freezer is unplugged or the power to the ULT freezer is interrupted, check the settings of the ULT freezer.

Items stored inside the ULT freezer may be adversely affected if the operation of the ULT freezer is resumed with changed settings.

- If the ULT freezer is unplugged or the power to the ULT freezer is interrupted, do not restart the ULT freezer for at least 5 minutes to avoid damage to the compressor or system.
- The filter screen shall be checked in time and cleaned. Dust-laden filter screens can cause temperature rise or failure in the ULT freezer.
- If the power plug has dust, it needs to be cleaned in time. Improper connection or plug filled with dust may cause heating or ignition.
- After the power is cut off or the power switch is off, the set point shall be checked when the power switch is restarted; otherwise, the stored items may be damaged due to setting change.
- Wear gloves during maintenance to avoid personal injuries caused by touching sharp edges or corners.
- The stored items shall not be contacted directly by hand. Direct contact with the frozen items or the inner wall of the ULT freezer without gloves may cause frostbite.
- Close the door by holding the handle to prevent fingers from being pinched.
- Tilt the ULT freezer for 45° when handling or moving it.
- Be careful not to trip over the ULT freezer when handling the ULT freezer, so as to prevent damage to the ULT freezer or personnel injuries.
- Do not use door handles to lift or carry equipment to prevent damage to the ULT

freezer or personnel injuries.

- Do not use electrical appliances inside the storage compartment of the ULT freezer, unless they are of the type recommended by the manufacturer.

Product Features

This product is mainly used to preserve drugs, vaccines and reagents.

It is applicable to hospitals, epidemic prevention stations, universities, scientific research institutes and electronic chemical industry enterprise labs.

Product Function

Precision temperature control Data traceability

- Computer temperature control, with a display accuracy of 0.1°C
- The temperature in the ULT freezer is uniform and controllable, the temperature range is adjustable to -86°C~-40°C, and the temperature control is accurate
- Standard USB port and traceable temperature data; query and save temperature data at any time

Efficient refrigeration Effective thermal insulation

- Imported compressor has the self-overlapping refrigeration and strong refrigeration capacity, and is safe and reliable
- High-performance VIP thermal insulation layer has the good thermal insulation effect
- Multi-layer 3D seal design effectively reduces refrigerating capacity loss and frosting

Multiple alarms Safety and stability

- Ideal function of audible and visual alarms to realize functions such as alarms for high and low temperature, power failure, and sensor fault; users may set the alarm temperature as needed
- Design of safety door lock improves the safety level of sample management

User-friendly design

- Adjustable shelf design ensures storage space available as required
- The LCD touch screen can be configured, with OTA function, displaying the temperature inside the ULT freezer and ambient temperature, and setting the high and low temperature alarm values and the ULT freezer temperature values as required, with the function of fault warning and early warning.

Note: The above features are not available for all models of products, and the detailed configuration shall be subject to the specific functions of each model.

Due to the continuous optimization of the product, the product you obtained may not be exactly consistent with the instructions. We sincerely apologize for this.

The contents of the manual are subject to change without prior notice.

Precautions for Use

- ★ When the ULT freezer is running, the contact part between the front of the ULT freezer and the outer door may be heated, which is not a fault. In order to prevent condensation around the ULT freezer housing, the heating condensate pipe is installed.
- ★ Before storing items in the equipment, check that the temperature in the storage compartment reaches the set temperature and then store the items in batches. The volume of each batch of items to be placed in the ULT freezer shall not exceed 1/3 of the volume inside the ULT freezer to prevent excessive temperature rise.
- ★ The displayed equipment temperature is the temperature at the temperature sensor in the storage compartment. There is a certain difference between the temperature displayed at the beginning of the operation of the equipment and the actual temperature in the center of the equipment, but as the equipment enters a stable state, the displayed temperature will gradually approach the actual temperature.
- ★ An inspection hole is installed on the enclosure of the equipment to pull out the testing line in the ULT freezer during the testing. After the testing line is pulled out, it is necessary to plug the testing hole again with thermal insulation material, otherwise the temperature in the ULT freezer may not reach the set temperature and cause condensation around the outside of the hole (applicable to ULT freezers with testing holes).
- ★ Please clean the equipment with a diluted neutral detergent. Do not use brushes, acids, gasoline, soap powder, polishing agents, or hot water for cleaning, otherwise the painted surface and plastic rubber parts may be damaged. Pay extra attention to not wipe plastic and rubber parts with volatile solvents such as gasoline.
- ★ When the ULT freezer is not in use for a long period, cut off the power supply and turn off the battery switch.
- ★ If the ULT freezer is not started again for a long time, a low battery level may occur. After the battery switch is placed at "ON", the battery can be charged, and the ULT freezer can run continuously for about one week to charge the battery (applicable to models with batteries).
- ★ Please minimize the time of opening the door during each access to the items, so as not to cause great fluctuations in the temperature and humidity in the ULT freezer.
- ★ After the door is opened, the temperature in the ULT freezer will rise sharply in a short time, which is normal, and it will return to set temperature of normal operation after the door is closed.
- ★ After the ULT freezer has been running for a period of time, a layer of frost is formed on the inner wall and inner door of the ULT freezer. If the frost layer is too thick, it will affect the thermal insulation effect of the ULT freezer and increase the power consumption. Therefore, after the frost layer reaches 5 mm, the attached shovel shall be used to defrost.
- ★ Before defrosting, the frozen items in the ULT freezer shall be taken out with ice shovel and put in a suitable environment for storage, to not damage the items due to temperature rise in the ULT freezer.
- ★ There are many refrigerating coils behind and on the side of the inner wall. The frost from the inner wall shall not be removed by sharp tools such as knife, ice chisel or screwdriver. The inner wall shall not be scratched during defrosting, or the ULT freezer will fail.

Product Installation

Installation Environment

- ★ Ambient temperature: 10 °C~32 °C; ideal temperature: 18 °C~25 °C; air conditioning system shall be used if necessary.
- ★ Ambient humidity: less than 80%Rh. The humidity shall be less than 60% Rh if the maximum operating temperature is 32 °C.
- ★ Avoid large amounts of dust.
- ★ Avoid mechanical sway or vibration.
- ★ Altitude of working position of ULT freezer: lower than 2000m.
- ★ Input voltage: 220V~240V, with a fluctuation within 10%.
- ★ Over-voltage level: II, Capacitance: 5KVA, IPX0.
- ★ Pollution level: 2.
- ★ The ULT freezer is sensitive to ambient temperature. If installed in an environment other than the above, the ULT freezer cannot operate normally. Please improve the environment before use.
- ★ Do not install the ULT freezer outdoors. Exposure to rain may cause an electric leakage or electric shock.
- ★ Transportation and storage conditions: Ambient temperature -40°C~+55°C, humidity 10~90% Rh

Installation Location

- ★ It shall not be installed in a narrow and closed space. The door body of the room where the ULT freezer is placed shall not be smaller than or lower than the ULT freezer, or at least the normal access of the equipment shall be ensured, so as to avoid maintenance difficulties in the event of equipment failure and causing damage to the stored items due to failure of repairing the equipment in time.
- ★ The floor on which the ULT freezer is installed must be sturdy and flat, non-flammable, and capable of bearing the weight of the equipment during operation.
- ★ The ULT freezer shall be installed in a well-ventilated location and not exposed to direct sunlight.
- ★ Each ULT freezer shall be provided with an independent power outlet. Please ensure that the outlet is capable of bearing a current $\geq 16A$, and the plug is firmly connected with the outlet. The power cord shall not be twisted or pressed.
- ★ Check the operating voltage before use. A voltage stabilizer suitable for the equipment load shall be considered to be used in areas with unstable voltages for voltage stabilization, and the power of the voltage stabilizer shall be greater than 4000W to ensure that the requirements for the input voltage in the installation environment are met.
- ★ The equipment shall be reliably grounded. If the power outlet is grounded, check whether it is properly grounded before use. If the outlet is ungrounded, it must be grounded by professional engineering technicians.



WARNING

- ★ Do not connect the grounding wire to a gas pipe, water pipe, telephone line, or lightning rod when grounding the unit, otherwise it may cause an electric shock.
- ★ After installation, the power plug must be accessible to facilitate timely unplugging of the power cord in case of emergency. Do not block the vent of the ULT freezer.



- ★ As the ambient temperature has a great impact on the equipment, if the above environmental requirements cannot be met, the equipment may not operate normally. Please improve the environment before using the equipment. The equipment operates intermittently.

Preparation before Use -----

- 1 Remove all transport packaging materials and belts.
- 2 Check the accompanying accessories. Please check the items in the box with reference to the packing list. If there is any discrepancy, please contact for after-sales service in time.
- 3 The placement conditions shall be such that clearances of at least 30cm are reserved around the ULT freezer for ventilation and heat dissipation.
- 4 Rotate the horizontal supporting feet clockwise with a wrench or manually to extend downward so that they are supported on the ground to ensure that the ULT freezer does not move when used.
- 5 Open the outer door by more than 90°, take out the shelf from the bottom of the ULT freezer, remove the shelf protective film, and place the shelf one by one on the shelf support strip.



- ★ Do not leave the plastic packing bags in a place where they can be reached by small children as this may result in suffocation accidents.

Initial Start -----

When using the equipment for the first time, please follow the following steps:

1. After the equipment is placed, leveled and cleaned, keep the ULT freezer still for more than 24 hours before connecting it to the power supply, so as to ensure the normal operation of the equipment.
2. Connect the power cord to a dedicated outlet of suitable specification under no load condition.
3. After the power supply is turned on, turn on the power switch of the equipment first; if the equipment is equipped with a battery, turn on the battery switch again (at the bottom of the rear side of the ULT freezer).
4. Set time parameter after the power supply is turned on.
5. Set the required temperature, do not put anything in the empty ULT freezer, power on and start up, check whether the operating temperature of the equipment reaches the required temperature, observe the normal startup and shutdown of the equipment for more than 24 hours, and demonstrate that the performance of the ULT freezer is normal.
6. Please store the items in batches, with the volume of each batch of items to be placed in the ULT freezer not exceeding 1/3 of the volume inside the ULT freezer. Ensure that the equipment is shut down and operates normally after being switched on and off for more than 8 hours before placing the next batch of items.
7. The door opening shall be minimized during the cooling process, otherwise the temperature will rise.

Operation after Power Failure

The set value is memorized by the equipment. After recovery from a power failure, the equipment will resume operation with the setting parameters before the power failure.



- ★ If the ULT freezer is unplugged or the power to the ULT freezer is interrupted, do not restart the ULT freezer for at least 5 minutes to avoid damage to the compressor or system.



- ★ When the ULT freezer is not in use for a long period, unplug the power plug and turn off the battery switch (applicable to ULT freezers with batteries) to prevent electric shock, electric leakage, or fire due to the deterioration of the power cord.
- ★ If the ULT freezer is to be stored unused in an unsupervised area for a long period, ensure that children do not have access to the ULT freezer and that doors cannot be closed completely.



- The product shall be managed by a specially-assigned person to check the operation and make records every day (it is recommended to record the inspection once every 2~4 hours). In case of failure or shutdown, the temperature in the ULT freezer will rise. If it cannot be repaired in a short time, the articles shall be transferred to other places that meet the temperature requirements for storage to avoid damage to the articles.
- This product is a ULT freezer. Please confirm in advance that the temperature required for the stored articles is consistent with the temperature range of the ULT freezer to avoid damage to the stored articles due to mismatch of the temperature range.
- Due to the inertia of refrigeration, there is a certain difference between the displayed temperature and humidity of this product and the actual temperature and humidity inside the ULT freezer, which is normal.
-  • Since all ULT freezers are storage equipment, it is strictly prohibited to put too many relatively hot items at one time, which will cause the compressor to not stop for a long time, the temperature will drop slowly and affect the service life of the compressor. The items must be put in batches to allow the temperature to decrease by steps until the required temperature is reached!
- Do not damage the refrigerating circuit.
- Do not use electrical appliances without production permits inside the ULT freezer.
- No mechanical tools or other means without the manufacturer's permission shall be used to accelerate the defrosting process.

Product Components and Overview

Schematic diagram of appearance

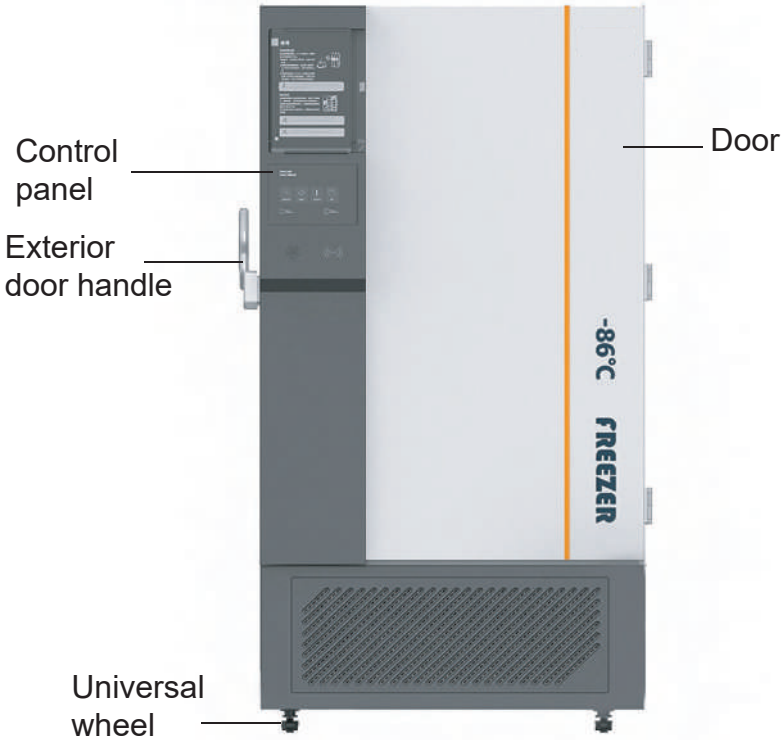

Due to the improvement of products and different models, the actual products may be different from the schematic diagrams. The actual configuration will depend on the physical product. The schematic diagrams are only for the description of functional parts.

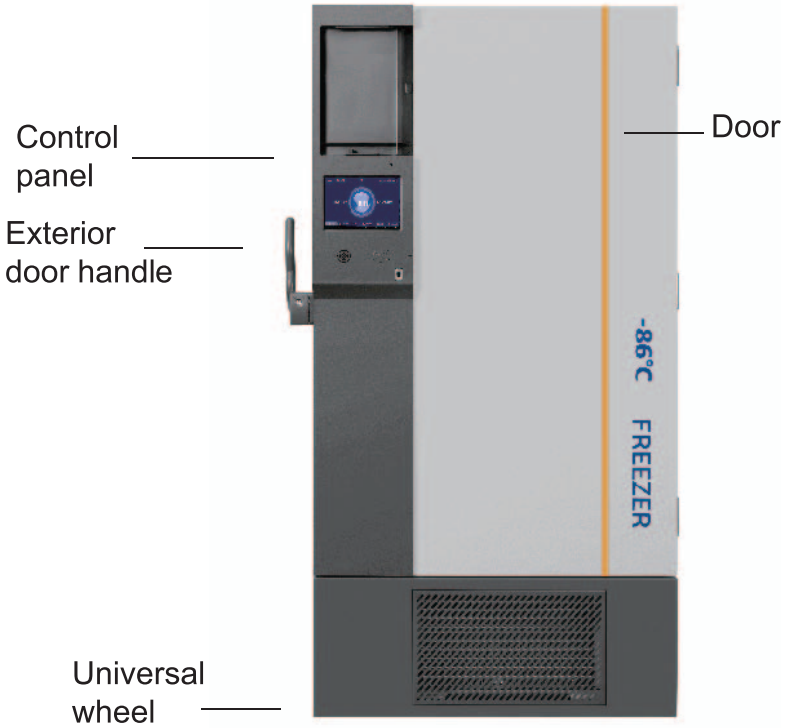

Due to the improvement of products and different models, the actual products may be different from the schematic diagrams. The actual configuration will depend on the physical product. The schematic diagrams are only for the description of functional parts.

Operating Instructions

Display panel

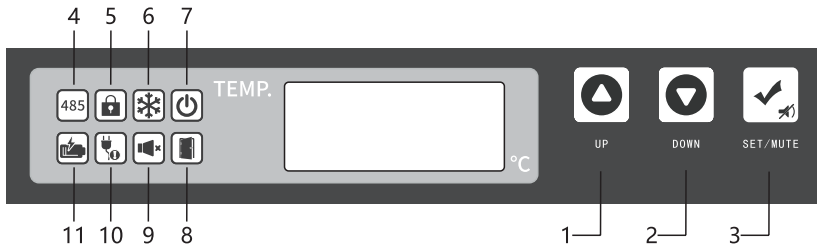

Description of buttons and icons

Button 1 - Up; Button 2 - Down; Button 3 - Setup/Mute.

Icon 4 - 485 communication; Icon 5 - Button locking; Icon 6 - Compressor startup; Icon 7 - Power-on; Icon 8 - Door opening; Icon 9 - Alarm silence; Icon 10 - Abnormal power supply; Icon 11 - Low battery level (all above are on)

Operation instructions

1. Check the ambient temperature

In the lock status of the keypad, press the "Setting/ Mute Multi-function Key" to display the ambient temperature on the LED segment display. Wait for 5 seconds without any keypad operation or press the "Up" or "Down" keys to return to the normal display.

In the unlock status of the keypad, press the "Setting/ Mute Multi-function Key" to display the ambient temperature on the LED segment display. Wait for 5 seconds without any keypad operation to return to the normal display.

2. Mute the alarm

When the alarm sounds, you can press the "Setting/ Mute Multi-function Key" to mute the alarm; then it will enter the status for checking the ambient temperature.

When the alarm is muted, you can press the "Setting/ Mute Multi-function Key" to restore the alarm sound; then it will enter the status for checking the ambient temperature.

In the unlock status of the keypad and the status for checking the ambient temperature, you can press the "Setting/ Mute Multi-function Key" to mute or restore the alarm sound.

3. Function of keypad lock

When the button is not locked, if there is no button operation for 60s or the Up and Down buttons are pressed at the same time for 3s (the buzzer sounds twice when the button is locked), the button is locked. In the button locked state, the ambient temperature and mute can be viewed, the rest of the button functions are locked, and the buzzer sounds twice during operation;

After pressing the Up and Down buttons at the same time for 3s, the digital tube will display "0000". Adjust the password to "5" through the Up and Down buttons. After the password is correct, return to the normal display, and the buzzer will sound once.

4. Parameter setting

When the button is not locked, press and hold the Setup/Mute button for 3s, and the digital tube displays "PS1". Press the Setup/Mute button to switch the menu and corresponding parameters, and press the Up and Down buttons to select the menu or adjust the parameters. Save the parameters after no button operation for 60s or by pressing and holding the Setup/Mute button for 3s, and exit with the buzzer for one sound.

Every time when the pharmacy refrigerator reconnected to power after a power failure, display automatically shows 1、 2、 3、 4、 5、 6、 7、 8、 9、 n in turn, users can set parameters as in below table while n is displayed.

Menu	Menu description	Setting range	Default	Unit
Set	Temperature setting	-86.0~-40.0	-81.0	°C
H	Upper deviation for alarm of high temperature	0.0-10.0; 0: Cancel the alarm	10.0	°C
L	Lower deviation for alarm of low temperature	0.0-10.0; 0: Cancel the alarm	10.0	°C
n	Set the current time - year	--	--	/
y	Set the current time - month	--	--	/
r	Set the current time - day	--	--	/
s	Set the current time - hour	--	--	/
F	Set the current time - minute	--	--	/
PT	Print interval	0~240	20	min
tH1	Alarm value of high temperature in ambient temperature	20.0~80.0	36.0	°C
Ps1	User menu password setting	0-9999	5	/
b1	Hardware version	--	2.0	/
b2	Software version	--	2.1	/

"Year" setting example

Steps	Operation	Display shows
1	Display shows n	n
2	Press Set/Mute key	
3	Press Up key, Down key to change parameter to targeted year	
4	Press Set/Mute key	
5	Press Set/Mute key 3s to save parameter and quit	

"Month" setting example (other r,s,F,Pt,SCY setting refers to this example)

Steps	Operation	Display shows
1	Display shows n	n
2	Press Up key, Down key to choose settable parameter "y"	y
3	Press Set/Mute key	
4	Press Up key, Down key to change parameter to targeted month	
5	Press Set/Mute key 3s to save parameter and quit	

Please finish setting in 2 minutes, it will automatic quit and shows normal if no operation.

5. Export of USB temperature data

When the USB flash disk is connected to the USB port, the buzzer will buzz once, and the screen will display the code "on" of date upload. PDF files with the data of the current and the last months will be generated and imported will buzz once, the screen will display "End" and return to normal display after 6s.

Screen Display Panel

1. Log in

a. Log in

There are three ways to log in: an account and password; a keycard (to match the model); and fingerprint scanning (to match the model)

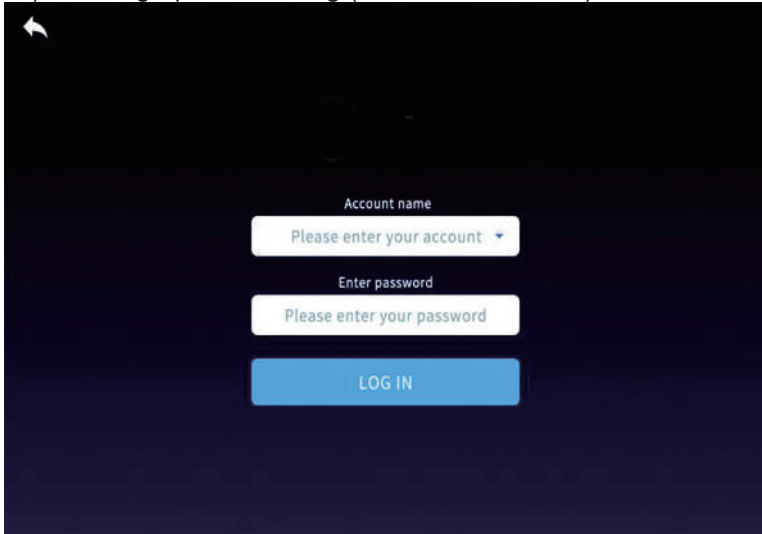

(Picture 1)

b. Visitors

Only authorized to view the data. Not for further operations.

2. Home

2.1 Normal state

There's a door icon on the right of the status bar, showing whether the door of the freezer is open or closed. Normally, it's closed. It shows otherwise when the door of the freezer is open. If the purchased product has an electromagnetic lock, the user can lock or unlock it by tapping the lock icon on the upper right.



(Picture 2)

2.2 Alarm

a. Alarm on

An alarm will pop up with a buzzing sound when there's a problem in functioning, to remind the user to deal with it promptly.

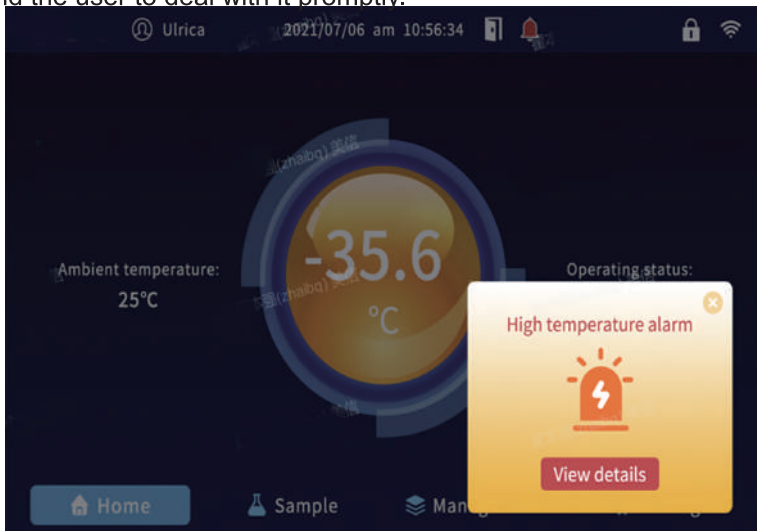

(Picture 3)

b. Alarm off

If there's a disorder, but it can't be repaired immediately, the user can tap the "alarm clock" icon to shut down the buzzer and close the alarm.



(Picture 4)

3. Sample

3.1 Stock in and out

Choose the freezer rack, freezer box, and well. Operate according to needs.

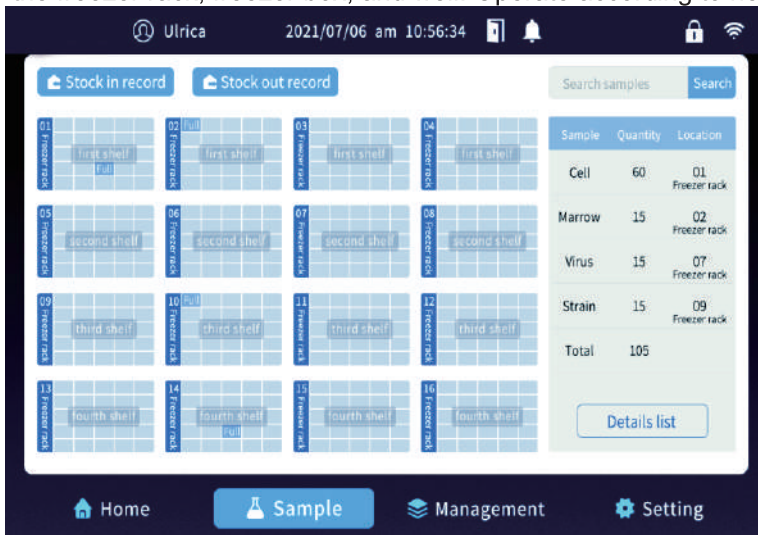

(Picture 5)

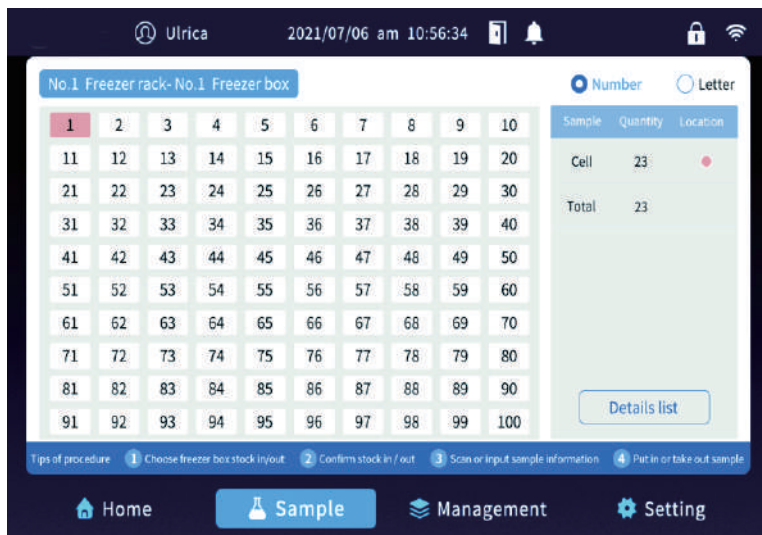

(Picture 6)

For example, tap the No. 1 Well in picture 7 for stock in; tap a well with samples for stock out.

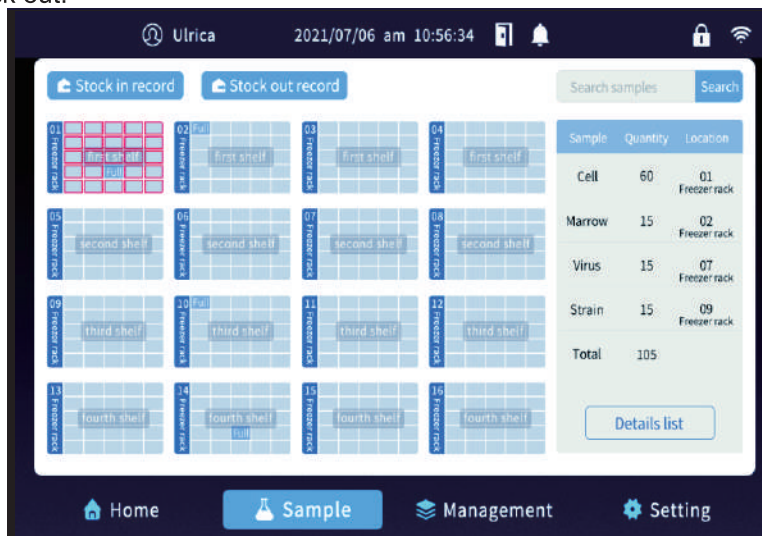

(Picture 7)

- a. The user can scan the sample code for stock in (insert the plug -and-play device into the USB on the right of the screen), or input the sample information for stock in confirm. There'll a notification of a success or failure, which will stop in one or two seconds.

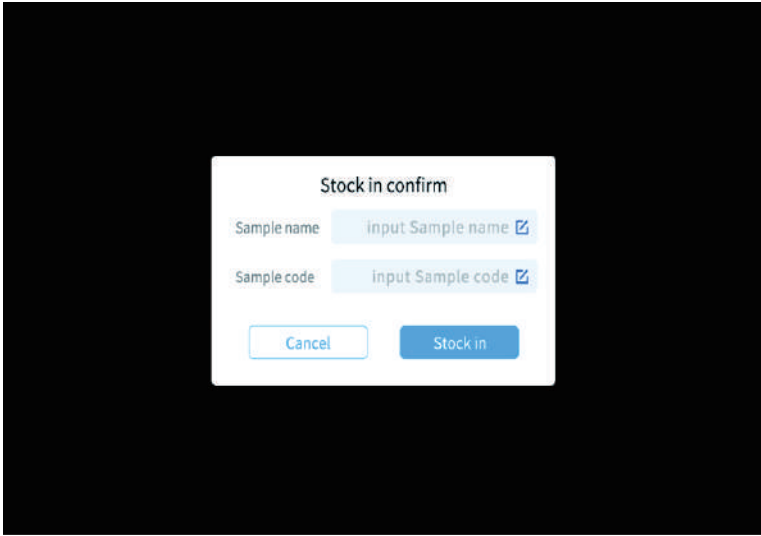

(Picture 8)

- b. The user can check the sample information for stock out confirm. After the sample is stocked out, there'll be a notification of a success, which will stop in one or two seconds.



(Picture 9)

3.2 Search Samples

- a. When the user searches samples, the locations of the searched samples will flash.

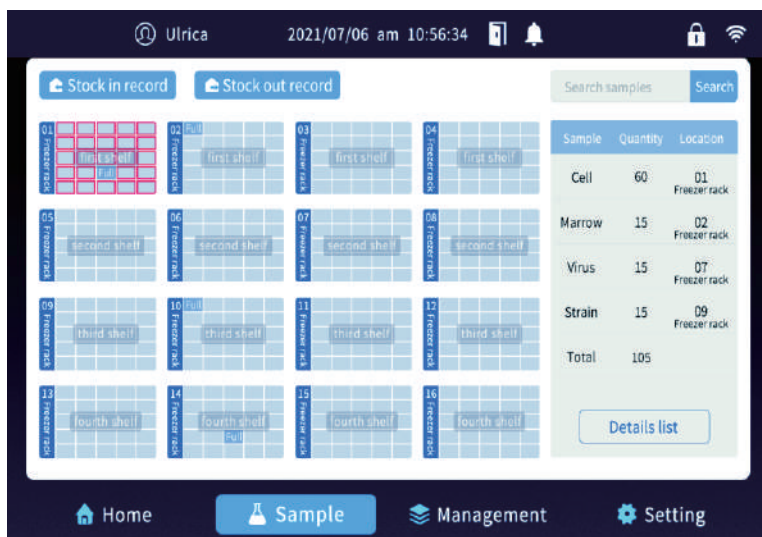

(Picture 10)

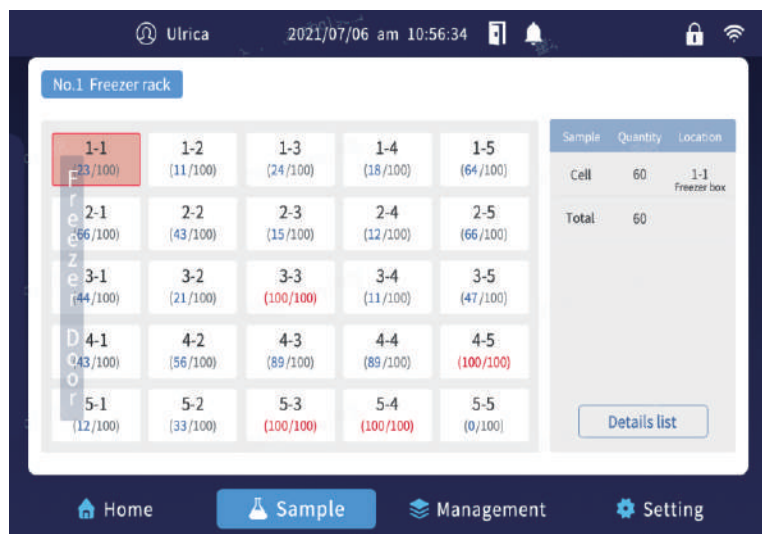

(Picture 11)



(Picture 12)

- b. If the location of the searched sample isn't in the display interface, there'll be a hand sign reminding the user to swipe right to view the data.

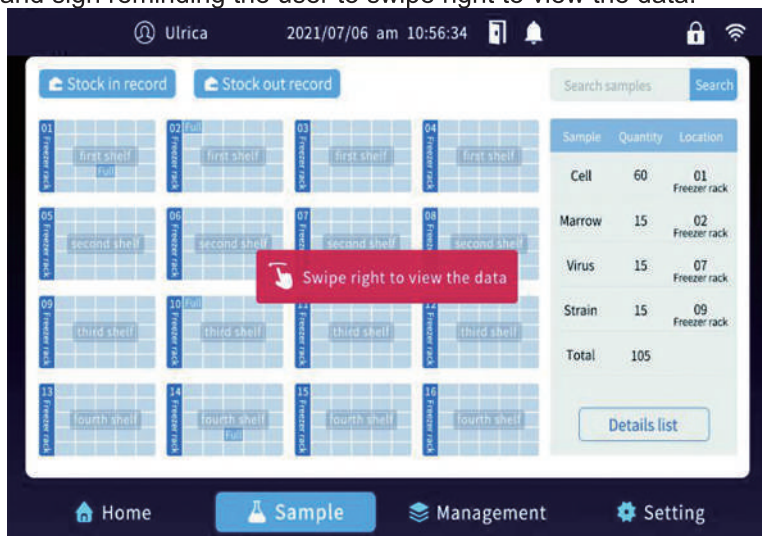

(Picture 13)

It's like this after the user swipes right.

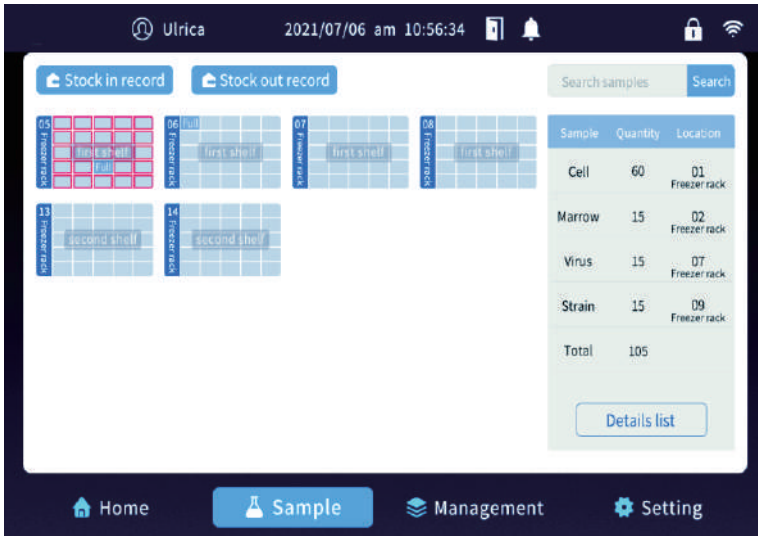

(Picture 14)

3.3 Stock in record



(Picture 15)

3.4 Stock out record



Sample name	Sample code	Stock in time	Stock out time	Storage location	Stock inwards operator
Cell	=DJNO156513213213	2021/07/09 14:54	2021/07/17 12:13	No.1 Freezer rack No.1 Freezer box-No.1 Well	Ulrica
Cell	=DJNO156513213213	2021/07/09 14:54	2021/07/17 12:13	No.1 Freezer rack No.1 Freezer box-No.1 Well	Ulrica
Cell	=DJNO156513213213	2021/07/09 14:54	2021/07/17 12:13	No.1 Freezer rack No.1 Freezer box-No.1 Well	Ulrica
Cell	=DJNO156513213213	2021/07/09 14:54	2021/07/17 12:13	No.1 Freezer rack No.1 Freezer box-No.1 Well	Ulrica
Cell	=DJNO156513213213	2021/07/09 14:54	2021/07/17 12:13	No.1 Freezer rack No.1 Freezer box-No.1 Well	Ulrica
Cell	=DJNO156513213213	2021/07/09 14:54	2021/07/17 12:13	No.1 Freezer rack No.1 Freezer box-No.1 Well	Ulrica
Cell	=DJNO156513213213	2021/07/09 14:54	2021/07/17 12:13	No.1 Freezer rack No.1 Freezer box-No.1 Well	Ulrica
Cell	=DJNO156513213213	2021/07/09 14:54	2021/07/17 12:13	No.1 Freezer rack No.1 Freezer box-No.1 Well	Ulrica

(Picture 16)

3.5 Details list

There's a details list for freezer racks, freezer boxes, and wells. It's displayed according to the content.



Sample code	Sample name	Stock in time	Storage time	Quantity	Storage location
=DJNO156513213213	Cell	2021/07/17 12:13	12 days 3 hours 12 minutes	3	No.1 Freezer rack No.1 Freezer box-No.1 Well
=DJNO156513213213	Cell	2021/07/17 12:13	12 days 3 hours 12 minutes	1	No.1 Freezer rack No.1 Freezer box-No.1 Well
=DJNO156513213213	Cell	2021/07/17 12:13	12 days 3 hours 12 minutes	2	No.1 Freezer rack No.1 Freezer box-No.1 Well
=DJNO156513213213	Cell	2021/07/17 12:13	12 days 3 hours 12 minutes	4	No.1 Freezer rack No.1 Freezer box-No.1 Well
=DJNO156513213213	Cell	2021/07/17 12:13	12 days 3 hours 12 minutes	3	No.1 Freezer rack No.1 Freezer box-No.1 Well
=DJNO156513213213	Cell	2021/07/17 12:13	12 days 3 hours 12 minutes	1	No.1 Freezer rack No.1 Freezer box-No.1 Well
=DJNO156513213213	Cell	2021/07/17 12:13	12 days 3 hours 12 minutes	1	No.1 Freezer rack No.1 Freezer box-No.1 Well
=DJNO156513213213	Cell	2021/07/17 12:13	12 days 3 hours 12 minutes	2	No.1 Freezer rack No.1 Freezer box-No.1 Well
=DJNO156513213213	Cell	2021/07/17 12:13	12 days 3 hours 12 minutes	2	No.1 Freezer rack No.1 Freezer box-No.1 Well

(Picture 17)

4. Management

4.1 Main interface

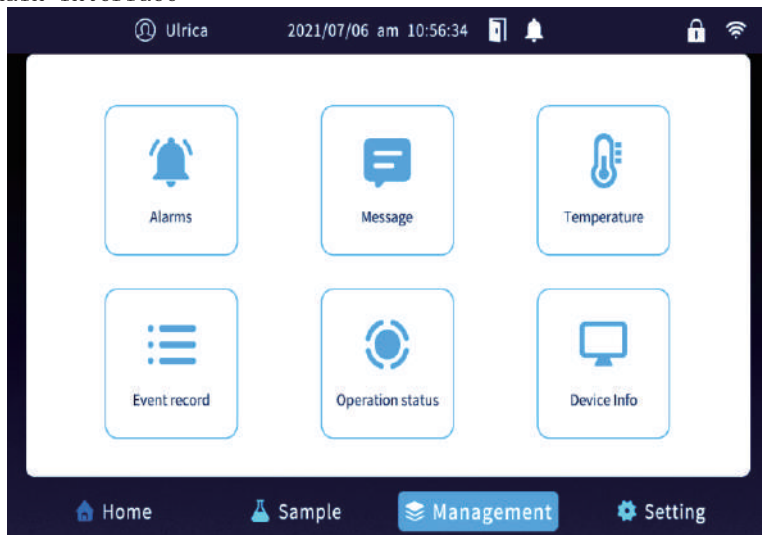

(Picture 18)

4.2 Alarm

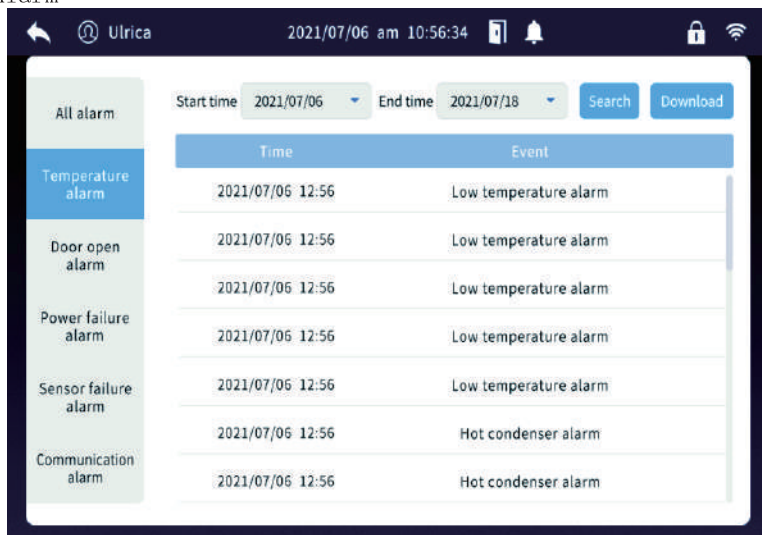

(Picture 19)

4.3 Message

a. New message

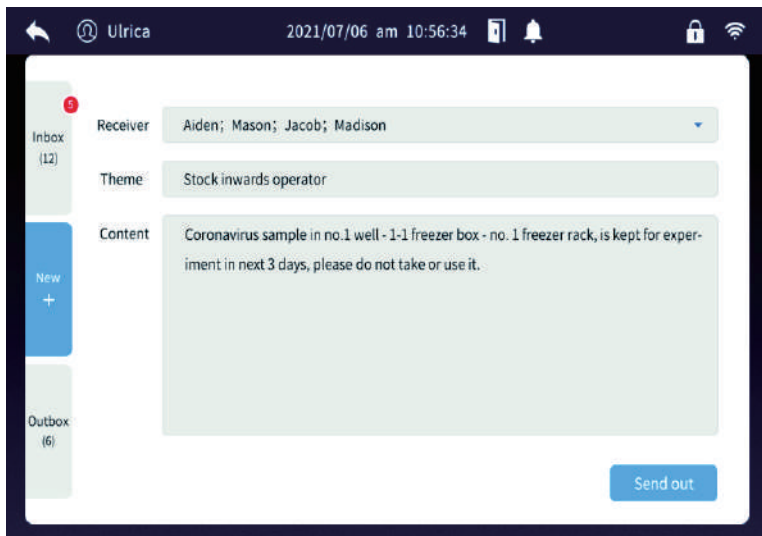

(Picture 20)

b. Inbox

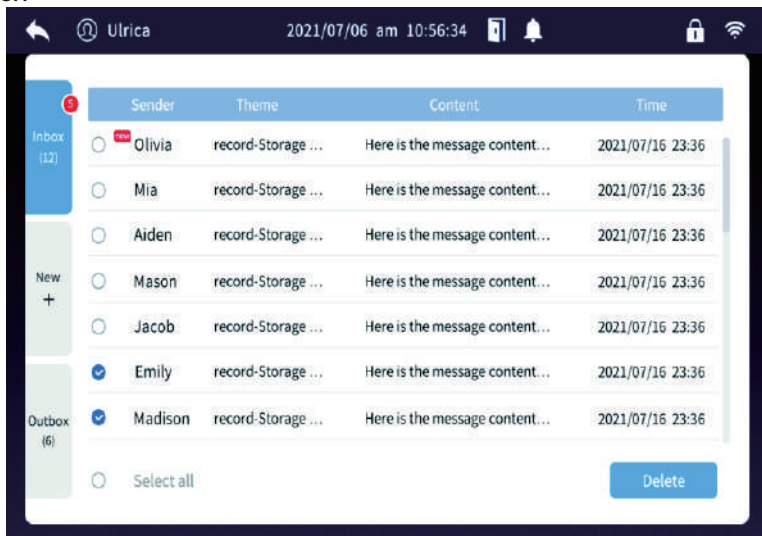

(Picture 21)

c. Outbox

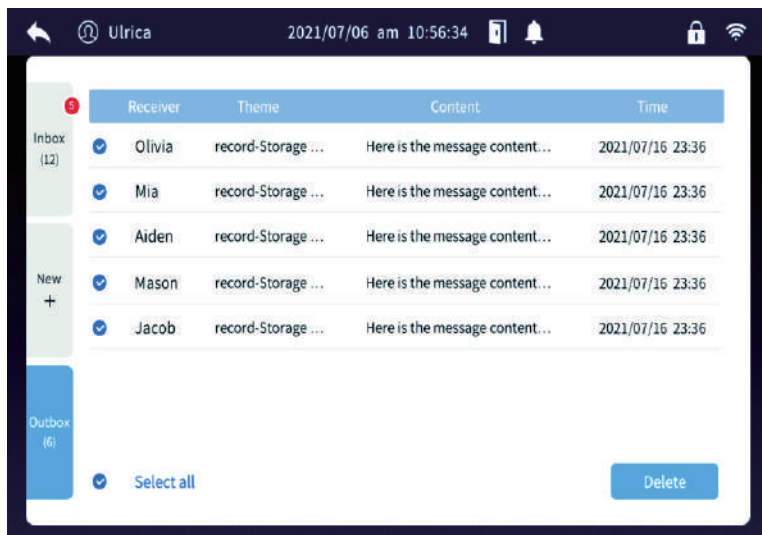

(Picture 22)

4.4 Event record

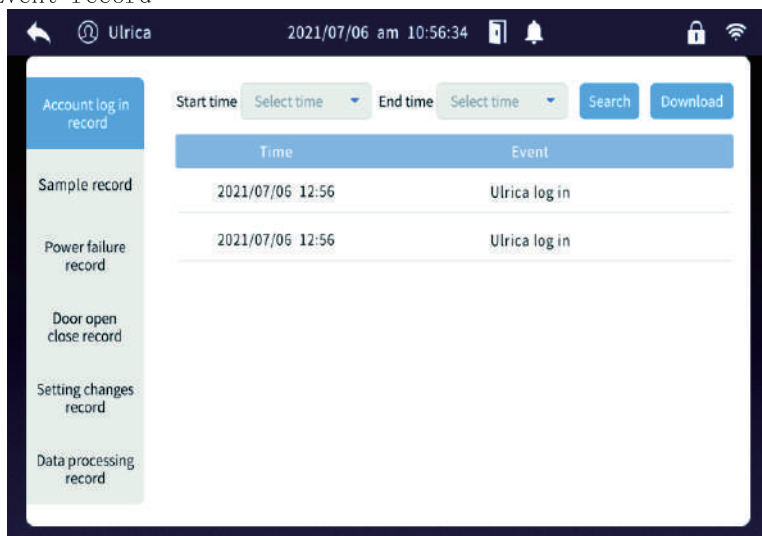

(Picture 23)

4.5 Operation status

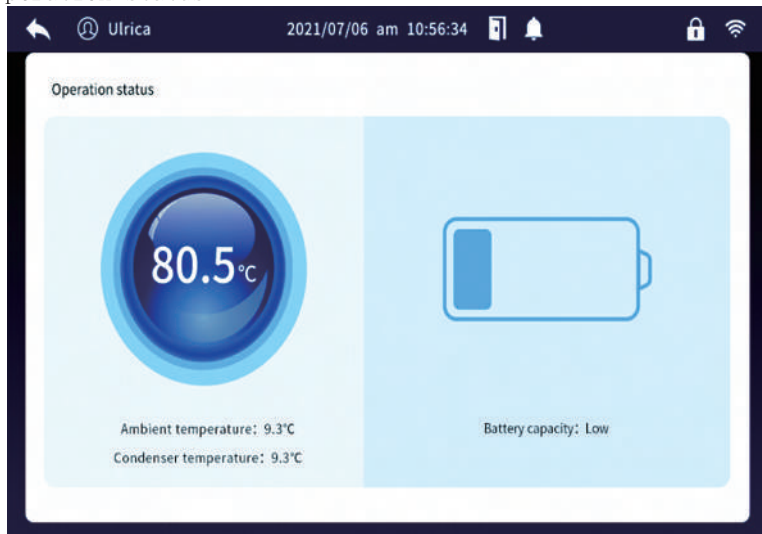

(Picture 24)

4.6 Device info

The name can be changed, but model name and machine code can't.

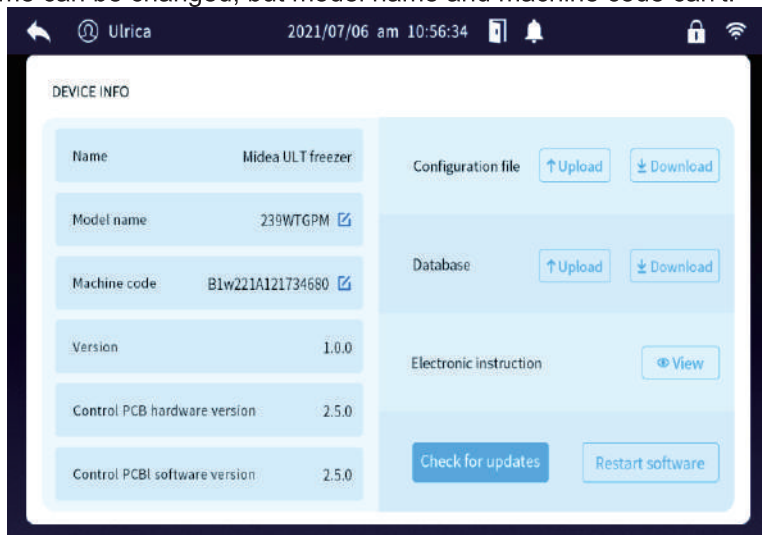

(Picture 25)

4.7 Main interface

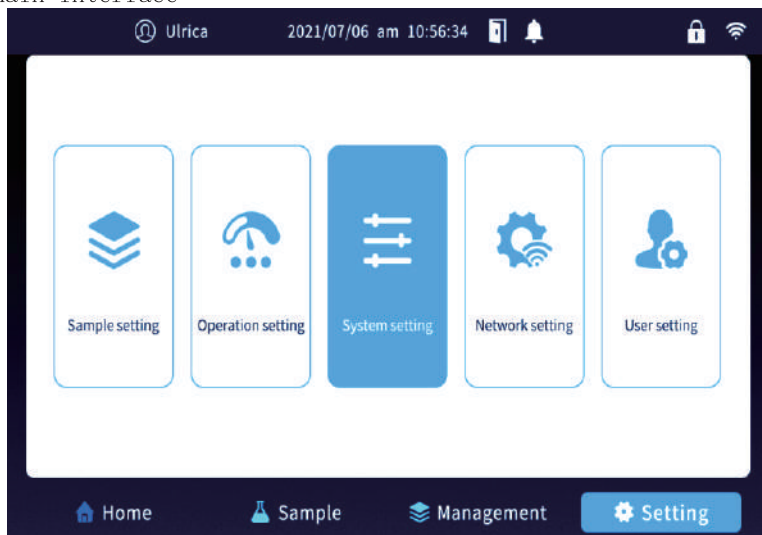

(Picture 26)

4.8 Sample setting

Setting range of freezer rack quantity: 3~8; freezer rack row and line: 5*5 or 5*4; freezer box specification: 10*10 or 9 *9

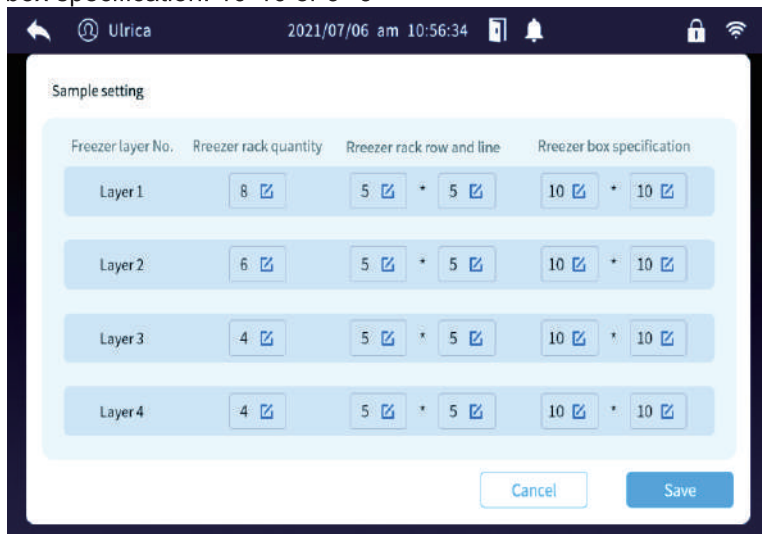

(Picture 27)

4.9 Operation setting

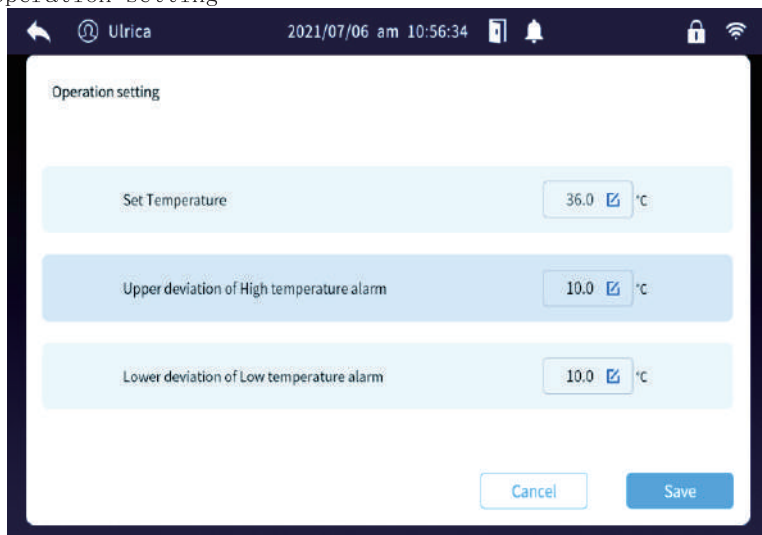

(Picture 28)

4.10 System setting

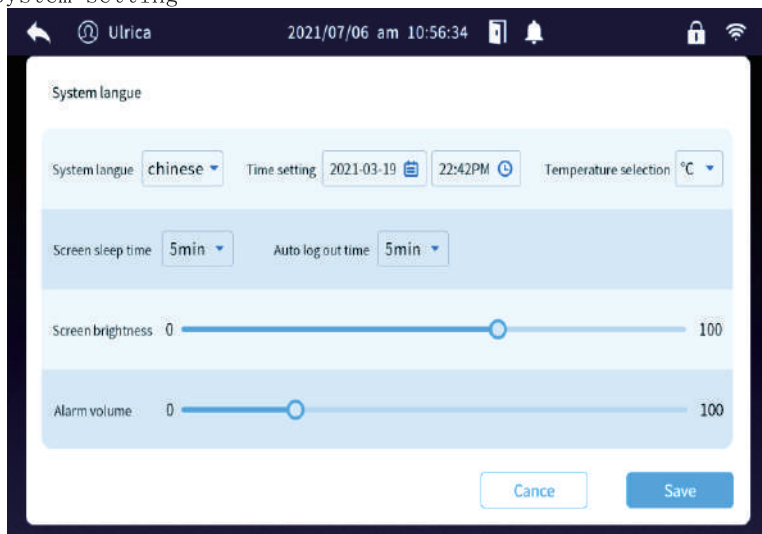

(Picture 29)

4.11 User setting

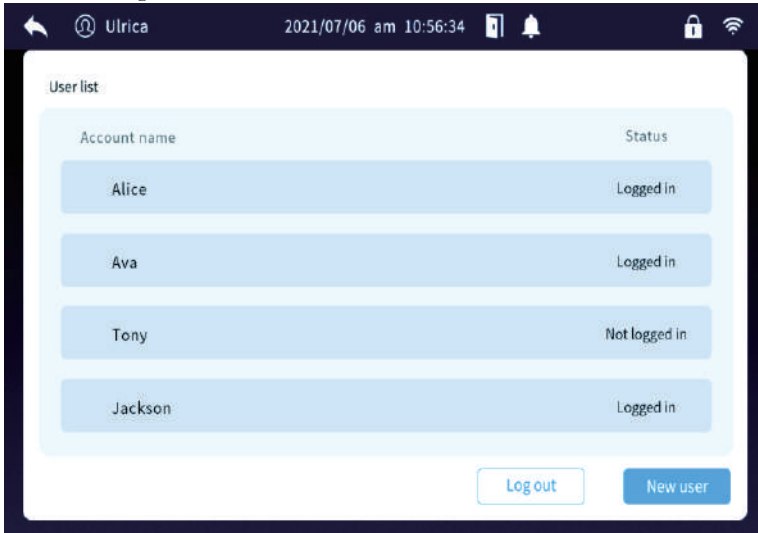

(Picture 30)

Tap "new account": the user can add the first account without having to log in on a new device. To add other accounts, the user has to log in with the first account.

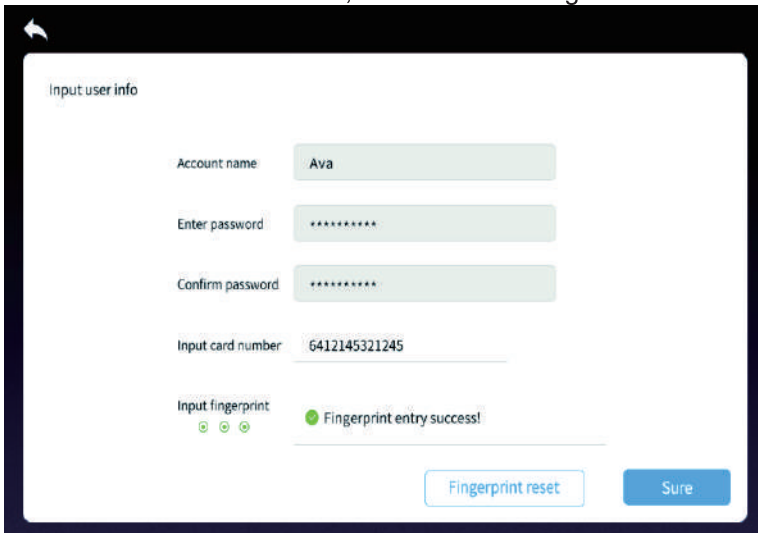

(Picture 31)

Alarm Description

S/N	Alarm codes	Meaning	Triggering conditions
1	H1	Alarm for high temperature inside the ULT freezer	An audible and visual alarm is given when the temperature inside the ULT freezer exceeds the alarm threshold for excessive temperature.
2	L1	Alarm for low temperature inside the ULT freezer	An audible and visual alarm is given when the temperature inside the ULT freezer exceeds the alarm threshold for too low temperature.
3	H2	Alarm for high ambient temperature	Ambient temperature is above 36°C
4	H3	Alarm for high condenser temperature	1. The condenser filter screen is dirty and blocked. 2. The condenser fan fails
5	Do	Door opening alarm	The outer door is opened for more than one minute
6	PF	Power-off alarm	Equipment loses power
7	bL	Low battery alarm	The battery capacity is too low or the battery warning switch is not on during the test. Indicators flash.
8	E1~E4	Alarm for sensor fault	The temperature sensor, ambient temperature sensor or condenser sensor in the ULT freezer fails.
9	Er	USB data recorder fault alarm	When the recorder is not shielded, the digital tube displays Er when the recorder is not connected;
10	Pr	USB generation file error	The digital tube displays Pr in case of USB generation file error
11	LoF	Recorder not started	In the unlock status of the keypad and when the recorder is not started, the alarm lamp flashes, and the screen displays "LoF". You can press the "Setting/ Mute Multi-function Key" and "Up" key for 3 seconds at the same time and the screen will stop displaying "LoF".

Maintenance



- ★ Always cut off the power supply before any repair and maintenance of the equipment to prevent electric shocks or personnel injuries.
- ★ Make sure that drugs or suspended particles from the surrounding environment will not be inhaled during equipment maintenance. Otherwise it may cause harm to human health.



- ★ Do not spray water directly on the ULT freezer, in case the insulation performance of electrical components decreases and metal parts get rusty.
- ★ Do not clean the ULT freezer with hot water, corrosive detergent, or organic solvent, etc.
- ★ Do not put heavy objects on top of the equipment in case it deforms under pressure.

Cleaning of ULT freezer

- 💧 The ULT freezer should be cleaned once a month. Regular cleaning keeps the ULT freezer a brand-new appearance.
- 💧 Wipe the dust off the ULT freezer's shell, inner chamber, and all accessories with a dry cloth. If the ULT freezer is dirty, wipe it with a cleaning cloth soaked with a neutral detergent to remove the dirt and wipe off the residual detergent with a wet cloth. Then, wipe it with a dry cloth again.
- 💧 Do not pour water onto the ULT freezer shell or into the ULT freezer. Otherwise, it may damage the electrical insulation, leading to a failure.
- 💧 The compressor and other mechanical parts are completely sealed and do not need lubrication.
- 💧 Clean the frost or ice on the inner wall and the condenser filter screen once a month.

Cleaning of condenser filter screen

The filter screen shall be cleaned once a month under normal use. If the filter screen is blocked, the refrigeration effect of the ULT freezer will be affected and the service life of the product will be reduced. Please clean the filter screen as follows. Do not move the sensor wire.

1. Remove the front bottom hood and the filter screen.
2. Clean the filter screen with water.
3. Blow off the dust on the condenser with compressed air.
4. After the filter screen is dried, put it back to its original position and install the hood.

Notes: The configuration of different product models is different, which is subject to the physical object.

Inner wall defrosting

Frosting may cause a gap between the ULT freezer and the door sealing strip, resulting in poor refrigeration. The inner door shall be defrosted with an ice shovel attached to the ULT freezer. The following steps are natural defrosting.

1. Shut down the auxiliary cooling device if any.
2. Remove items from the ULT freezer and transfer them to an environment suitable for storage.
3. Turn off the power supply
4. Open the outer and inner doors to allow the ULT freezer to open naturally for a period of time for defrosting.
5. Dry the accumulated water at the bottom of the ULT freezer with a piece of dry cloth.
6. After cleaning the ULT freezer and inner door, restart the ULT freezer.
7. Put the items back into the fully cooled ULT freezer.
8. If there is an auxiliary cooling device, restart the device.



Do not use knife, screwdriver or any other tool with a sharp edge to defrost.

Equipment shutdown

Shutdown: If the ULT freezer is not used in an unsupervised area for a long period, ensure that children do not have access to the ULT freezer and that doors cannot be closed completely.

Scrapping: The scrapping disposal of the ULT freezer shall be carried out by corresponding professionals. In order to prevent something like suffocation, the ULT freezer doors must be removed.

Optional Accessories

Temperature recorder

Please refer to the Temperature Recorder Instructions provided by the temperature recorder for use.



Please install the temperature recorder by professional technicians or after-sales personnel.



Please cut off the power supply before installing the temperature recorder; otherwise, electric shock or fire may occur.

Freezer racks and cryo boxes

When the ULT freezer stores small specifications of materials, freezer racks and cryo boxes can make more efficient use of space. The height of the racks may need to be properly adjusted.

Model	GL-U-16D	GL-U-19D	GL-U-25D	GL-U-30D
Matched freezer racks size (single) mm	140*549*293	140*685*293	140*685*293	140*685*293
Number of racks/drawers/hanging baskets	3	3	3	3
Number of inner doors	4	4	4	4
Number of freezer racks placed	16	16	20	24
Number of cryo boxes	320	400	500	600

Troubleshooting and Repairs

Any product may suffer a failure. Please observe the equipment operation during use. For any anomaly, please troubleshoot it by referring to the following table. If the problem persists, please contact our service center. We will serve you wholeheartedly to avoid losses.

Faults	Troubleshooting
ULT freezer does not work	Is the power circuit breaker normal?
	Is the power voltage too low?
	Is the power switch off?
	Is the fuse blown?
Poor cooling	Is the ambient temperature too high?
	Is the inner door closed tightly? Is the outer door closed tightly? (The frost between the ULT freezer and the door sealing strip may damage the door sealing performance)
	Is the air inlet dirty and blocked?
	Are the condenser and filter screen dirty and blocked?
	Is the temperature set correctly?
	Is the ULT freezer away from direct sunlight?
	Is the ULT freezer close to the heat source?
	Are the rubber hole cover and insulation material of the test through hole properly placed?
	Is a large amount of high temperature articles placed in the ULT freezer for a short time?
Loud noise	Is the ULT freezer installed on a solid and flat ground?
	Are other items contacted to the ULT freezer housing?
	Is the base of the ULT freezer leveled?



Note: If the fault cannot be eliminated after the above items are checked, or the fault is different from the above list, please contact the after-sales personnel.

Specification

Name	ULT freezer			
Model	GL-U-16D	GL-U-19D	GL-U-25D	GL-U-30D
Climate type	16~32°C			
Electrical shock protection class	Class I			
Electricity	220V~240V~/50Hz			
Temperature inside the box	(-86~-40)°C			
Refrigerant	R601a/100g R290a/10g R1150/25g	(Each separate refrigerant circuit) R601a/70g R290/7g R1150/18g	(Each separate refrigerant circuit) R601a/90g R290/9g R1150/23g	
Refrigeration method	Direct cooling			
Foam material	Cyclopentane			
Total effective volume	458L	568L	718L	838L
Input power (W)	1190	2210	2210	2030
Power consumption (kWh/24h)	11.3	15	17	14.3
Weight (kg)	237	286	305	332
Product Dimensions W*D*H (mm)	885*855*1980	885*995*1980	1030* 995*1980	1175* 995*1980
Rated current (A)	5.9	12	12	9.5
Noise (dB)	65			

Specification

Name	ULT freezer			
Model	GL-U-16D	GL-U-19D	GL-U-25D	GL-U-30D
Climate type	16~32°C			
Electrical shock protection class	Class I			
Electricity	220V~240V~/50Hz			
Temperature inside the box	(-86~-40)°C			
Refrigerant	R601a/100g R290a/10g R1150/25g	(Each separate refrigerant circuit) R601a/70g R290/7g R1150/18g	(Each separate refrigerant circuit) R601a/90g R290/9g R1150/23g	
Refrigeration method	Direct cooling			
Foam material	Cyclopentane			
Total effective volume	458L	568L	718L	838L
Input power (W)	1190	2210	2210	2030
Power consumption (kWh/24h)	11.3	15	17	14.3
Weight (kg)	237	286	305	332
Product Dimensions W*D*H (mm)	885*855* 1980	885*995* 1980	1030* 995* 1980	1175* 995* 1980
Rated current (A)	5.9	12	12	9.5
Noise (dB)	65			

Description of technical parameters: The technical parameters in this table are measured under standard conditions. After the parameters are changed due to product improvement and technical update, no further notice will be given, which shall be subject to the nameplate attached to the ULT freezer.

Packing List

Name	Manual	Key (Based on configuration)	Defrosting shovel	Handle (Based on configuration)
Quantity	1	2	1	1

Note: External padlock and handle optional accessories shall be subject to physical configuration.

Electrical Schematic Diagram

GL-U-16D

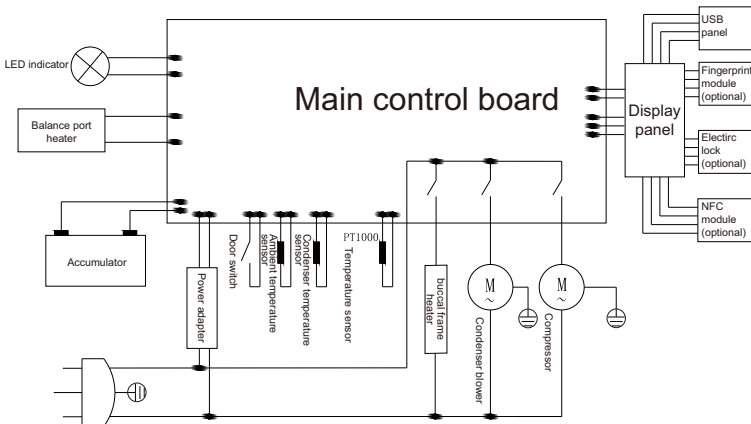

GL-U-19D, GL-U-25D

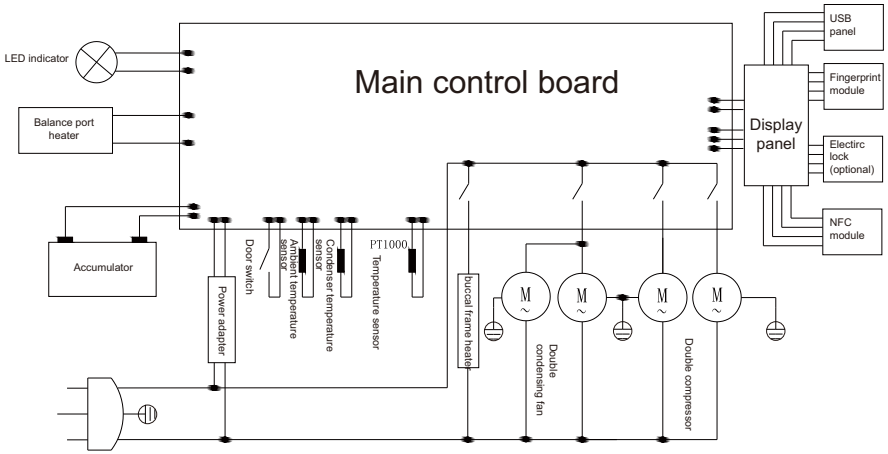

GL-U-30D

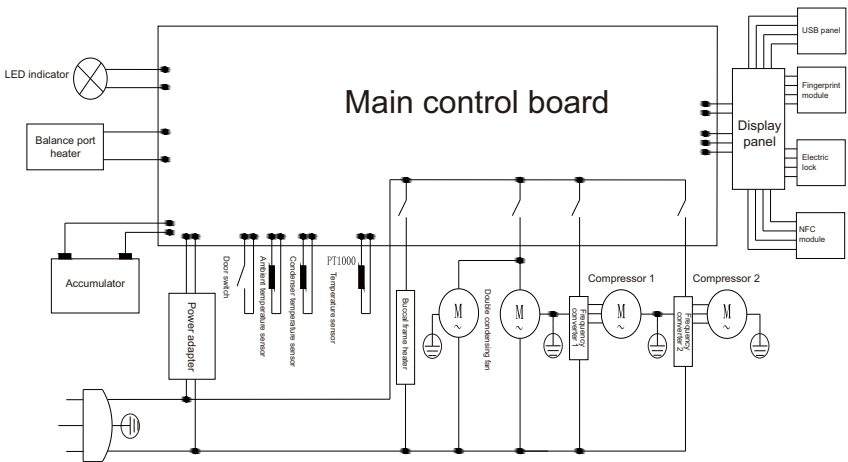

GL-U-16D

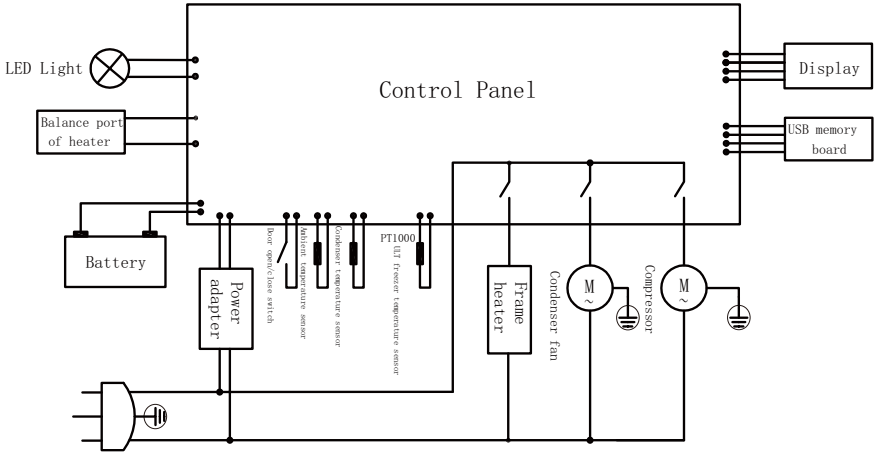

GL-U-19D, GL-U-25D

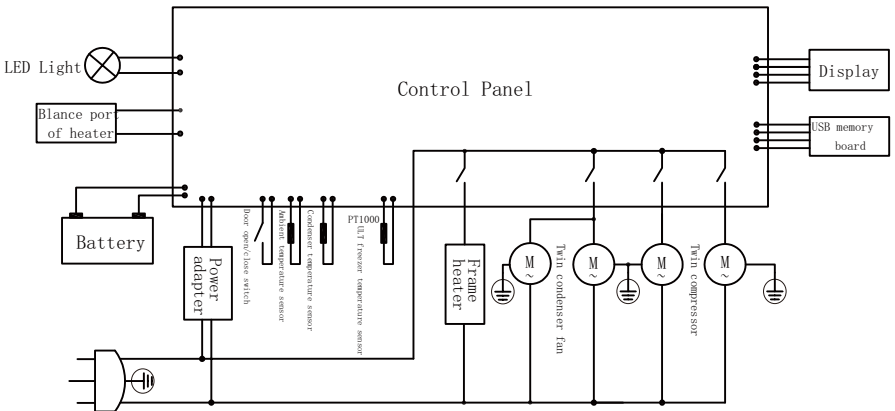

GL-U-30D

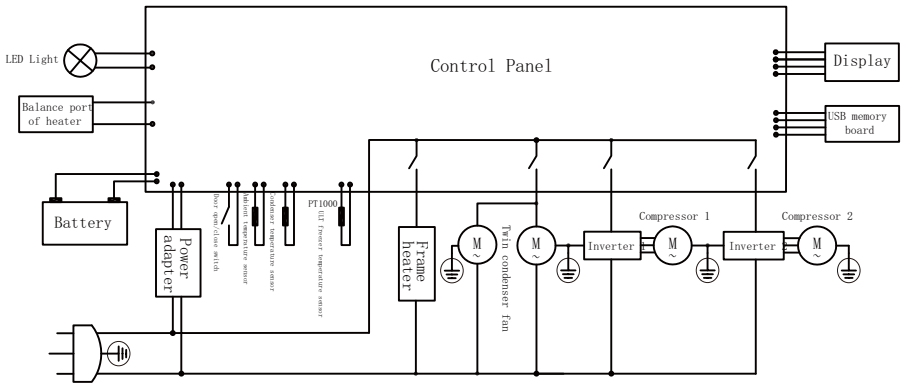

Service Guide

Precautions

- 1 This Warranty Card is properly kept by the customer and serves as a warranty certificate for the product together with the purchase invoice.
- 2 Since the date of purchase, failures caused by product manufacturing quality without unauthorized disassembly and repair during the "Three Guarantees" period can be repaired based on the Warranty Card and purchase invoice after being appraised by customer service department or special maintenance department, referring to the (GJM) Provisions on Liability for Replacement and Return of Some Commodities ("New Three Guarantees").
- 3 Damage caused by improper transportation, use, maintenance, custody or removal of non- "Three Guarantees" repairer, no Warranty Card and valid invoice, the model in the Warranty Card not matching with the model of repaired product or altered, and damage caused by force majeure are not covered by the warranty.

Definition of warranty period

This product shall be subject to free warranty during the warranty period from the date of purchase.

Free warranty conditions

- 1 Users who purchase ULT freezer series products and have gone through warranty registration procedures with our company.
- 2 A valid warranty certificate (Warranty Card) is provided and the name, model and bar code of the product to be repaired must be consistent with those in the Warranty Card. If a valid Warranty Card cannot be provided, the warranty shall be extended for 6 months based on the warranty period calculated from the date of delivery on the machine bar code.
- 3 The product must be within the warranty period
- 4 Failure is caused by non-human factors.

Date of manufacture: see bar code of ULT freezer

Expected service life: 10 years.

Product quality warranty

Complete equipment	Major Components	Note
One year	Three years	Main components include compressor, main control panel, display control panel, temperature controller, evaporator, condenser, filter, capillary and fan motor

(Note: In case of a separate warranty agreement, the agreement shall prevail.)